

2MP Vandal-resistant Network IR Fixed Dome Camera

IPC322ER-F28



Key Features

Optics

- Day/night functionality
- Smart IR technology
- Lowlight surveillance
- 3D DNR (Digital Noise Reduction)

Compression

- Triple streams
- ROI (Region of Interest)
- Customized OSD

Network

- ONVIF Conformance

Structure

- Support PoE power supply
- Wide temperature range: -35°C to 60°C (-31°F to 140°F)
- Wide voltage range of $\pm 25\%$
- IK10 vandal resistant
- IP66

Specifications

	IPC322ER-F28
Camera	
Sensor	1/2.8", 2 megapixel, progressive scan, CMOS
Lens	2.8mm@ F1.8; Angle of View (H): 108°
Shutter	Auto/Manual, 1/6~1/8000 s
Day/Night	IR-cut filter with auto switch (ICR)
Min. Illumination	Colour: 0.06 Lux (F1.8, 50IRE) Black & White: 0.03 Lux (F1.8, 50IRE)
S/N	>52dB
Image Rotation	Supported
Video	
Max. Resolution	1920×1080
Video Compression	H.264,MJPEG
Frame Rate	1080P (1920×1080): Max.30 fps; 720P (1280×720): Max. 30 fps; D1 (720×576): Max. 25 fps
ROI	Supported
Video Streaming	Triple
OSD	Up to 8 OSDs
Privacy Mask	Up to 4 areas
Audio	
Audio Compression	G.711
Two-way audio	Supported
Network	
Protocols	L2TP,IPv4,IGMP,ICMP,ARP,TCP,UDP,DHCP,PPPoE,RTP,RTSP,Qos,NTP,FTP,HTTP,SNMP,SIP
Compatible Integration	ONVIF, IMOS,API
Interface	
Audio I/O	Audio cable
	Input: impedance 35 kΩ; amplitude 2 V [p-p]
	Output: impedance 600 Ω; amplitude 2 V [p-p]
Alarm I/O	1 / 1
Network	10M/100M Base-TX Ethernet
General	
Power	12 V DC, or PoE (IEEE802.3 af)
	Power consumption: 3.5W (5.5W with IR on)
Dimensions (∅ x H)	∅109 x 81 mm (∅4.3" x 3.2")
Weight	0.45 kg (1.0 lb)
Working Environment	-35°C ~ +60°C (-31°F ~ 140°F), Humidity ≤ 90% RH(non-condensing)
Vandal Resistant	IK10
Ingress Protection	IP66

Dimensions

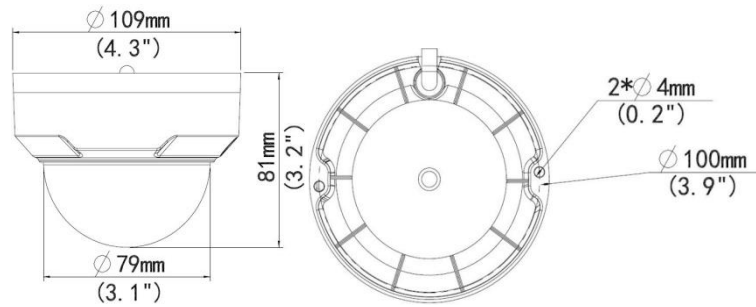

Installation

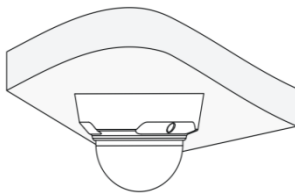

Ceiling mount

Accessories

Installation mode	Accessories	Description
Ceiling mount	Mounting pedestal is included in the Product package	

Zhejiang Uniview Technologies Co., Ltd.

South Tower, Building 10, Wanlun Science Park, 88 Jiangling Road, Hangzhou, P.R.China 310051

Email: overseasbusiness@uniview.com; globalsupport@uniview.com

<http://www.uniview.com>

©2015 Zhejiang Uniview Technologies Co., Ltd. All rights reserved.

*Product specifications and availability are subject to change without notice.